

MALE END VIEW

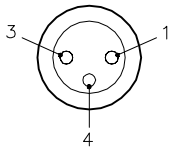

1 = BROWN
3 = BLUE
4 = BLACK



SPECIFICATIONS

| | |
|-------------------------------|-----------------------------------|
| CONTACT CARRIER MATERIAL | NYLON OR TPU |
| MOLDED HEAD MATERIAL/COLOR | TPU/GRAY |
| CONTACT MATERIAL/PLATING | BRASS/GOLD |
| RATED CURRENT [A] | 4.0 A |
| RATED VOLTAGE [V] | 125 VAC/VDC |
| OUTER JACKET MATERIAL/COLOR | PVC/BLACK |
| CONDUCTOR INSULATION MATERIAL | PVC |
| NUMBER OF CONDUCTORS [AWG] | 3x24 AWG |
| TEMPERATURE RANGE | -40°C to +105°C (-40°F to +221°F) |
| PROTECTION CLASS | MEETS IEC IP67 |

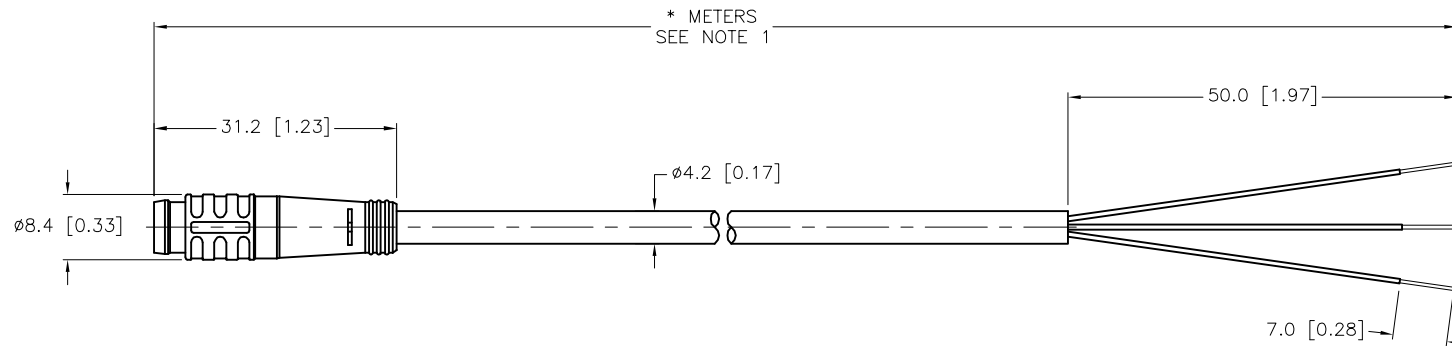

| CABLE LENGTH | TOLERANCE* |
|--------------|---|
| ALL LENGTHS | + 4% (OR 50mm) OF LENGTH - 0% (OR 0mm) OF LENGTH WHICHEVER IS GREATER |
| STRIP LENGTH | TOLERANCE* |
| 0-7mm | ±0.5mm |
| 8-29mm | ±1.0mm |
| 30-49mm | ±2.0mm |
| 50-69mm | ±3.0mm |
| 70-100mm | ±4.0mm |
| OVER 100mm | ±5.0mm |

*UNLESS OTHERWISE SPECIFIED

SOURCE DRAWING - FOR REFERENCE ONLY

NOTES:

- "*" INDICATES CABLE LENGTH IN METERS. CONTACT TURCK TO ORDER SPECIFIC LENGTHS.
- "/S760" DESIGNATES BLACK CABLE JACKET.
- "/S1057" DESIGNATES GRAY MOLDED PLUG BODY MATERIAL.
- "/S1579" DESIGNATES NO FLAG LABEL, BAG LABEL ONLY.

| | | | | | | |
|---|---|--|---|--|---------------------------|---|
| RELATED DOCUMENTS 1. 2. 3. 4. | 3RD ANGLE PROJECTION | THIS DRAWING IS CONFIDENTIAL AND THE PROPERTY OF TURCK INC. USE OF THIS DOCUMENT WITHOUT WRITTEN PERMISSION IS PROHIBITED. | | 3000 CAMPUS DRIVE MINNEAPOLIS, MN 55441 1-800-544-7769 (763) 553-7300 (763) 553-0708 fax www.turck.us | | |
| | | DRFT | RWC | DATE | 11/27/07 | DESCRIPTION PSG 3-*/S760/S1057/S1579 |
| MATERIAL SEE SPECIFICATIONS | ALL DIMENSIONS DISPLAYED ON THIS DRAWING ARE FOR REFERENCE ONLY | APVD | | SCALE | 1=1.0 | |
| FINISH SEE SPECIFICATIONS | | CONTACT TURCK FOR MORE INFORMATION | UNIT OF MEASUREMENT MILLIMETER [INCH] | | IDENTIFICATION NO. | REV D |
| D | UPDATE PROTECTION CLASS | CBM | 08/22/23 | 79048 | | |
| REV | DESCRIPTION | BY | DATE | ECO NO. | DO NOT SCALE THIS DRAWING | |
| | | | | | FILE: 777020650 | SHEET 1 OF 1 |